



MONITORING SERVICES (U.K.) LTD



Radio Telemetry Load Indicators

**Quick and Simple Load
Checking, Testing,
Measurement & Weighing**

Totally Portable Operation

**Standard Range 2 to 120
Tonnes**

**Lightweight & High Strength
Aluminium Link Body**

**Worldwide Licence Exempt
2.4GHz Operating Frequency**

Range min 100m

**Battery Life: Active Not less
than 70 Hours**



FACT SHEET



USES

Mobile and tower cranes
 Check weighing
 Tension measurement
 Construction operations
 Testing

FEATURES

Light weight aluminium body for ease of transportation and installation.
 Battery life: Active- not less than 70 Hrs
 Battery Type: Link- 2 x type AA
 Handheld- 4 x type AA
 "Power on" system test and calibration check.
 Illuminated 15mm digits
 Operating Frequency: 2.4GHz
 Proof Load: 200% Working Load Limit
 (150% for 55t and above)
 Ultimate Load: 7 Times Working Load Limit
 Ambient Temp: -10°C to +40°C
 Accuracy: $\pm 1\%$ of ACTUAL Reading
 Radio: Built in compliance with:
 U.S.A. :-FCC P14-TDK-BTISM
 EURO :-CE 0700
 Range: Not less than 100m under normal conditions
 Link: Weatherproofed to IP65
 Push Button Tare
 Peak Hold
 Push button Unit Conversion (T,kg,lb,T_i,T_s)

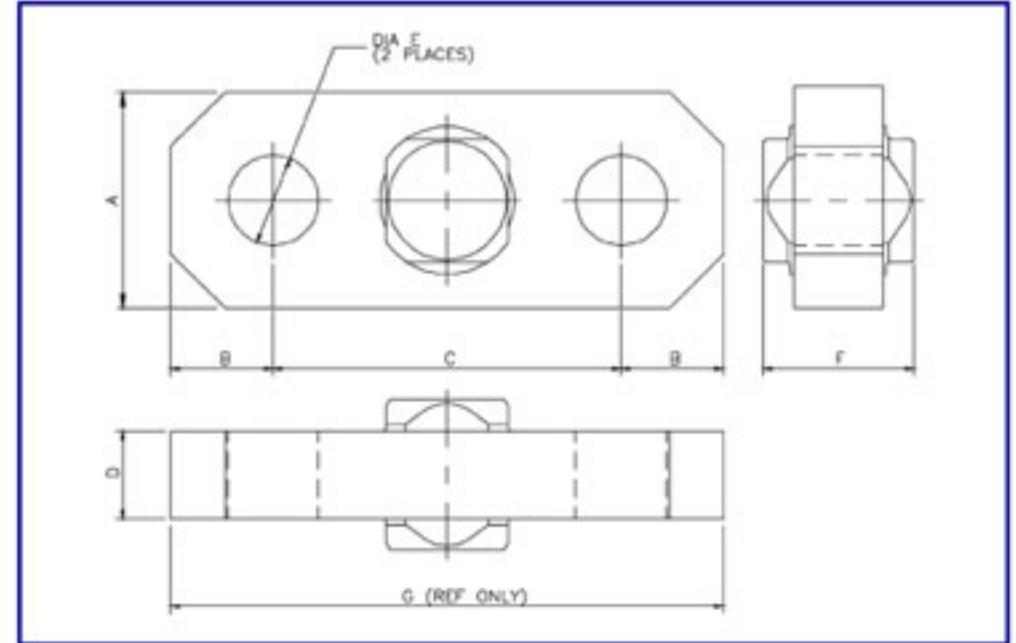

Load capacity (tonnes)	A	B	C	D	ØE	F	G
2	100	47	166	34	28	74	260
6.5	100	47	166	34	28	74	260
12	100	58	176	40	37	80	292
25	125	75	220	55	53	95	370
55	150	108	254	85	73	125	470
120	220	160	320	115	98	155	640

All dimensions in millimeters (unless otherwise stated)

Load Capacity (tonnes)	Link Weight (Approx)	Shackle Crosby G2130	
		W.L.	Size
2	2.5kg	6.5T	7/8"
6.5	2.5Kg	6.5T	7/8"
12	6.5Kg	12.0T	1 1/4"
25	7.0Kg	25.0T	1 3/4"
55	14.5Kg	55.0T	2 1/2"
120	40.0Kg	120.0T	3 1/2"

Link Material - Aluminium Alloy



For further information visit:
www.safe-t-weigh.com

LBD Hire Pty Ltd
 (08) 9355 4216

With a policy of continuous improvement, the above specification is subject to alteration. Please confirm any critical factor prior to order. Calibration to BS EN ISO 7500-1:1999

